



Applications

Designed for use as a replacement in most plastic and ceramic exposed and concealed cisterns

Also supplied as standard or as an optional extra in Dudley cisterns

Complies fully with water regulations:

- ~ True AG Air Gap
- ~ No under water joints
- ~ No silence tube

Water Saving

Delay fill saves water and supports BREEAM by only allowing a cistern to start refilling once flushing is complete.

Features

- ~ Compact body and float assembly
- ~ Key supplied for simple and safe removal of the filter
- ~ Unique float arm makes it impossible for the float to become detached
- ~ 3 available options of quiet fill technology...

Valve Option	Fill Nozzle		Flow Control		WRAS Approved
	Standard	Enhanced	Restricted	Regulated	
Standard	✓		✓		✓
Enhanced		✓	✓		✓
Flow Regulated		✓		✓	✓

- ~ Enhanced option offers integrated quiet fill action
- ~ Flow Regulated option includes integrated quiet fill action together with 6 litre per minute flow control for ultimate quiet fill performance.



Dimensional Data

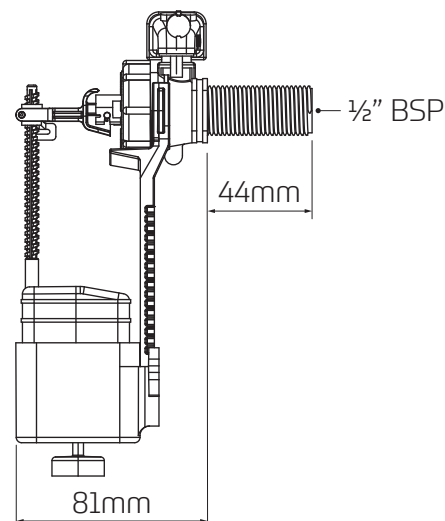

Technical Data

Connection	1/2" BSP plastic tail
Adjustment	65mm float height range
Valve Type	Diaphragm
Float	Compact (Delay-fill)
Conformity	BS 1212-4